

平行气爪

(C)KH(L)系列



◆小型、轻量

采用连杆机构, 小型、轻量。

◆易于对中

平行气爪与V型气爪相比, 对中更方便、通用性更广。

◆长寿命

滑动部使用回转支承轴承, 寿命长。

◆本体尺寸相同〈(C) KHL系列〉

与无开关KHL的本体尺寸及安装尺寸相同, 具有互换性。

◆开关位置可调〈(C) KHL系列〉

可调节开关位置, 通过夹指开闭的确认及微调, 可对工件直径的确认进行调节。

◆继承了KH系列的特点, 并且开闭行程长

〈(C) KHL系列〉

◆两个面上均设有气孔, 可根据安装状态选

用其中之一〈(C) KHL系列〉

(C)KH(L)系列

平行气爪

平行气爪

(C)KH(L)系列

■ 型号表示记号

C KHL - 16

开关型号

C : 带开关时
无记号 : 无开关

缸径

16: 16mm
20: 20mm
32: 32mm (仅长行程)

系列名

KH : 标准行程
KHL : 长行程

■ 内部结构图

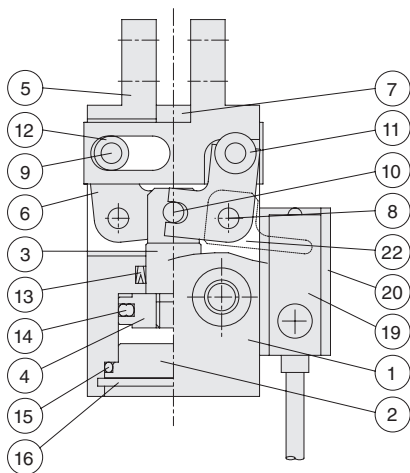

零件表

序号	名称	材质
1	本体	铝合金
2	尾盖	铝合金
3	活塞杆	碳钢
4	活塞	铝合金
5	夹指	碳钢
6	动作杠杆	碳钢
7	轨道	碳钢
8	支点销	碳钢
9	滑动销	碳钢
10	活塞杆销	碳钢
11	轨道环	碳钢
12	杠杆环	碳钢
13	活塞杆密封件	NBR
14	活塞密封件	NBR
15	O形环	NBR
16	固定环	硬钢
19	开关	
20	开关安装板	树脂
22	检测板	硬钢



规格

使用流体	空气
最大使用压力 [MPa]	0.7
耐压 [MPa]	1.05
使用环境温度范围 [°C]	0~60 (无冻结)
注 油	不需要 (机械滑动部需要)
配管口径	M5×0.8
最大使用频率 [Cycle/min]	120 (KHL=80)
重复精度 [mm]	±0.1
适用开关	GX-F8A (仅限CKH(L)) 参见P.527

动作方式	型 号	缸 径 [mm]	最小使用压力 [MPa]	开闭行程 [mm]	夹持力 [N]		外形尺寸 (高×宽×长) [mm]	产品质量 [g]
					闭合时	开启时		
双作用型	KH-16	16	0.2	5	14	18	25×25×42.5	104
	CKH-16						25×35×42.5	119
	KHL-16	16	0.2	10	14	18	25×32×49.5	142
	CKHL-16						25×42×49.5	157
	KH-20	20	0.2	6	19	25	32×32×51	212
	CKH-20						32×42×51	227
	KHL-20	20	0.2	12	19	25	32×50×57	273
	CKHL-20						32×60×57	289
	KHL-32	32	0.2	16	78	90	40×50×69.5	513
	CKHL-32						40×60×69.5	529

注) φ16的夹持力为夹持点L=20、压力0.5MPa时的有效值。
φ20、φ32的夹持力为夹持点L=30、压力0.5MPa时的有效值。

(C)KH(L)系列

平行气爪

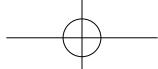

平行气爪

(C)KH(L)系列

■有效夹持力(闭合力)

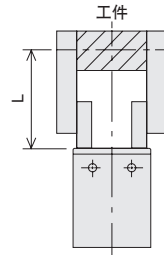
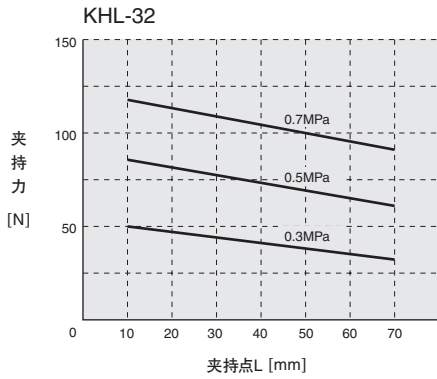
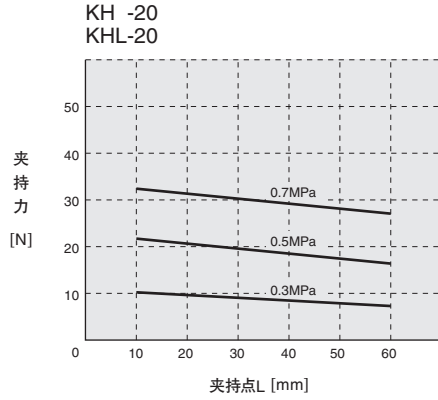
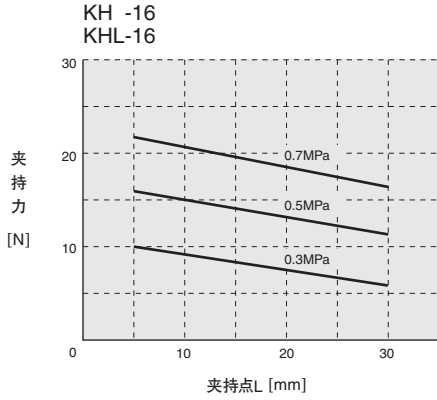

(C)KH(L)系列

平行气爪

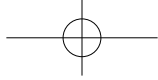

外形尺寸图 KH-16

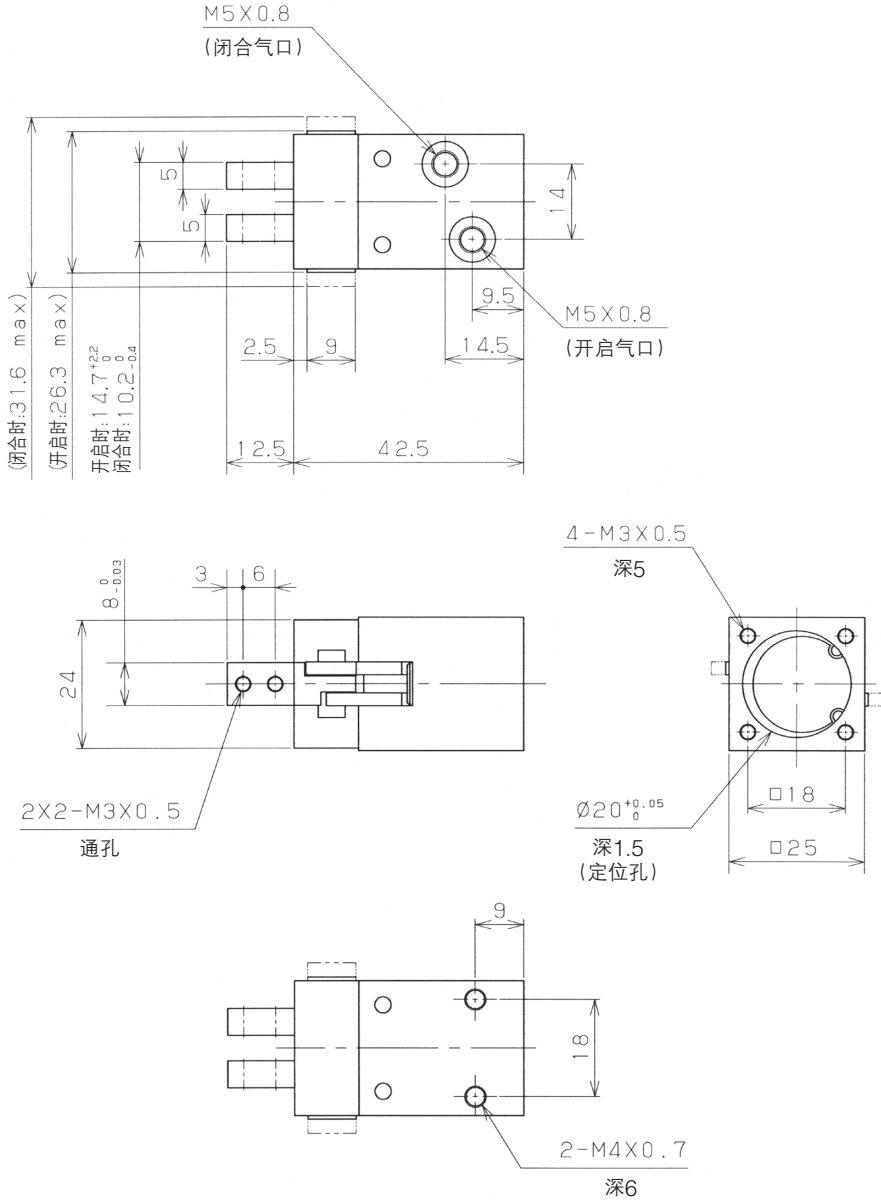

(C)KH(L)系列

平行气爪

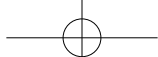

平行气爪

(C)KH(L)系列

备有CAD数据

外形尺寸图 KH-20

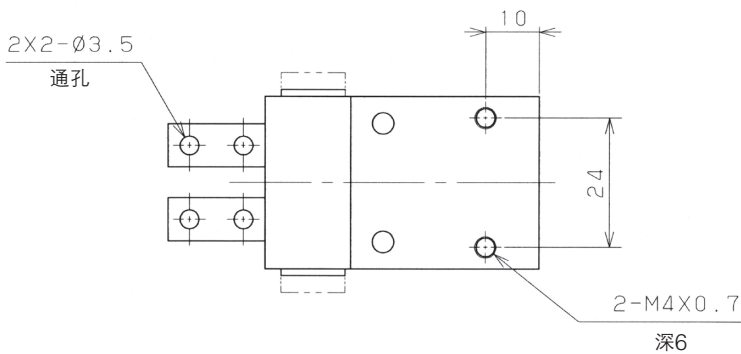
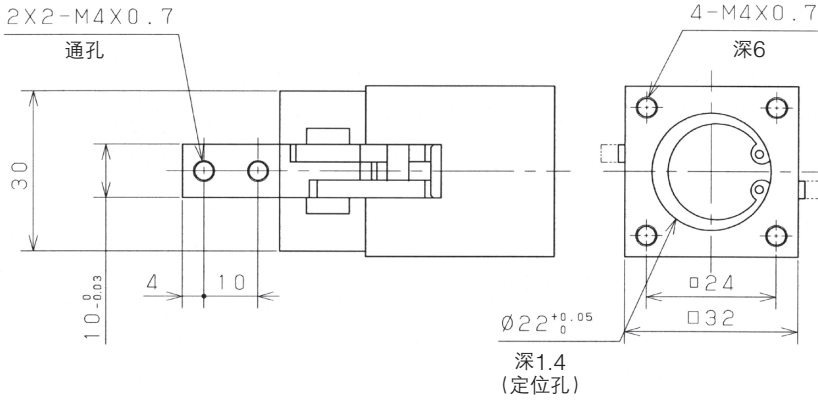
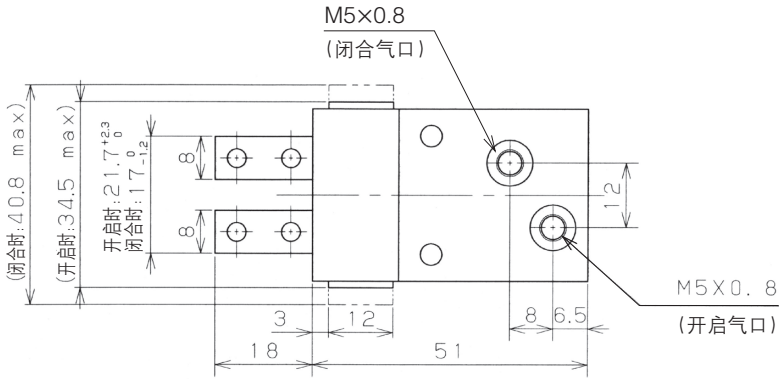

(C)KH(L)系列

平行气爪

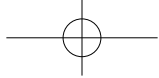

外形尺寸图 CKH-16

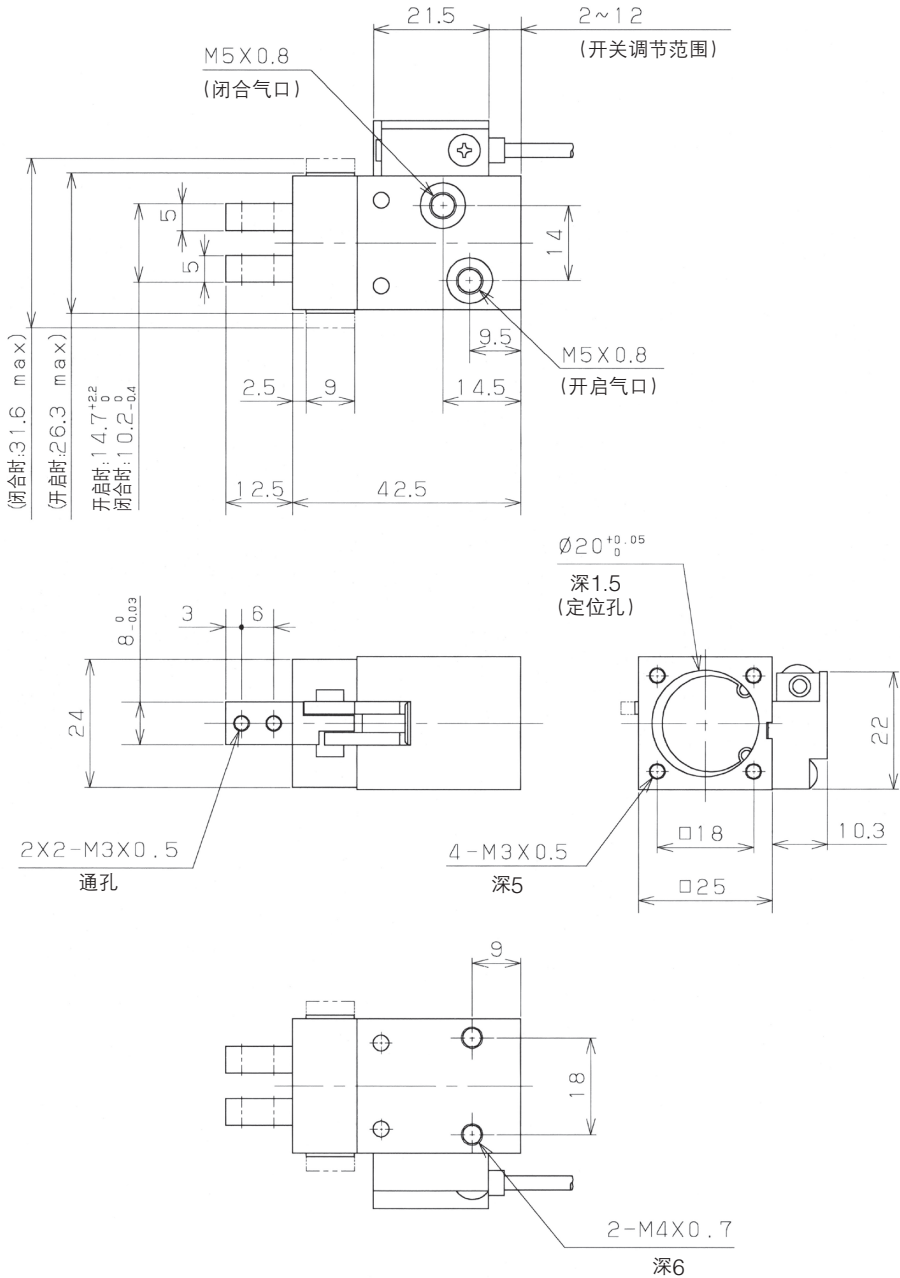

CKH(L)系列

平行气爪

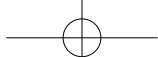

平行气爪

(C)KH(L)系列

备有CAD数据

外形尺寸图 CKH-20

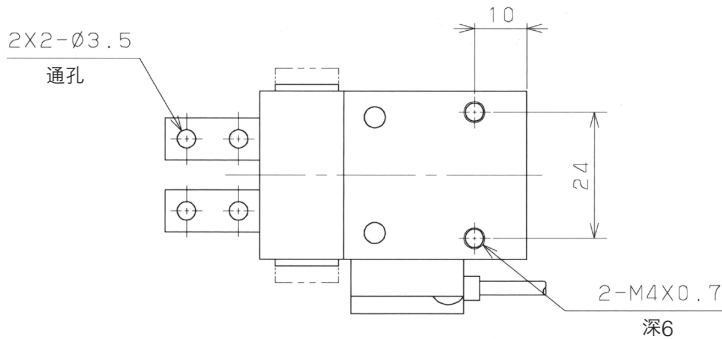
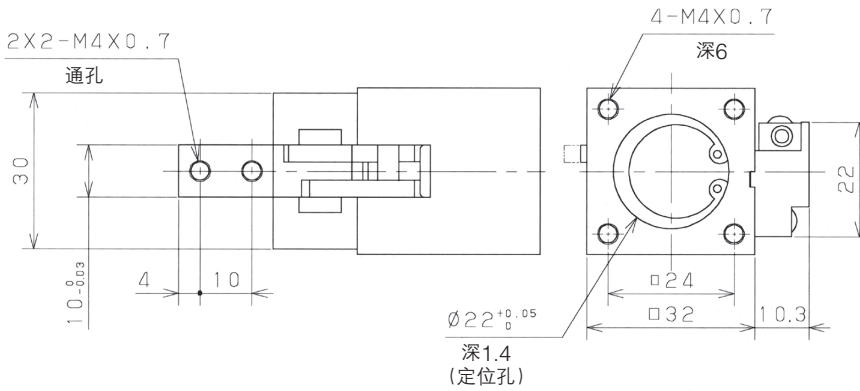
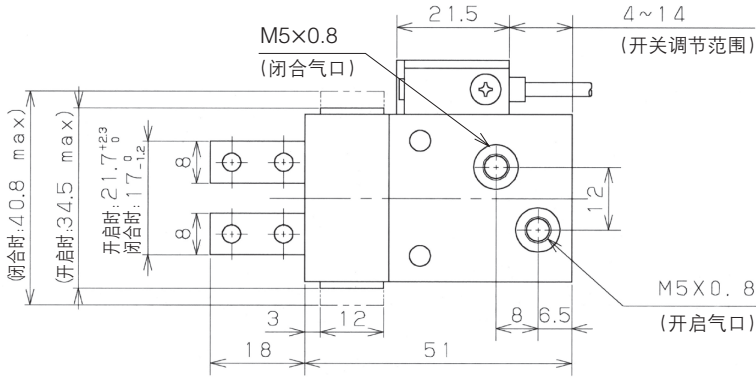

(C)KH(L)系列

平行气爪

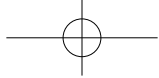

外形尺寸图 KHL-16

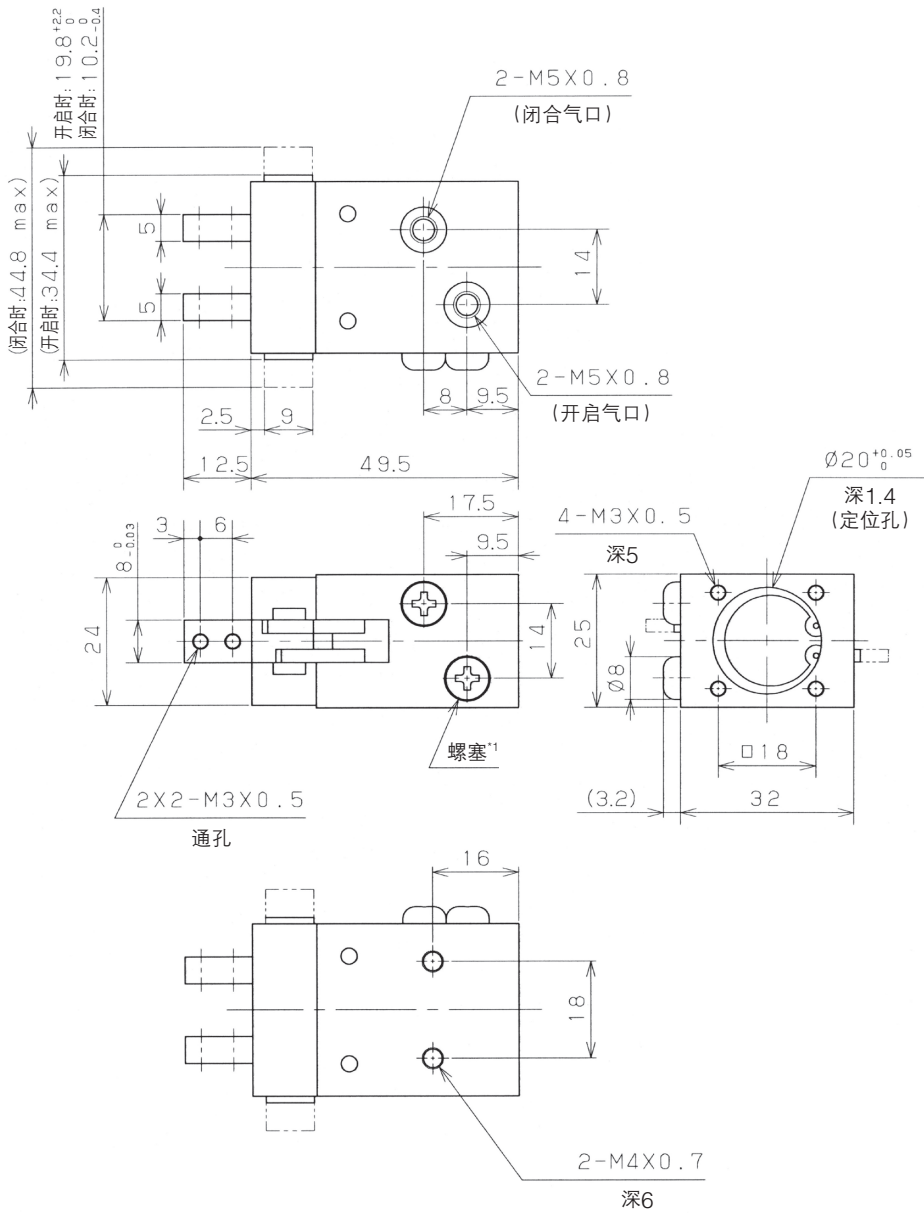

*1) 两个面上均设有气口, 请根据安装状态选用。

(C)KHL系列

平行气爪



平行气爪

(C)KH(L)系列

备有CAD数据

外形尺寸图 KHL-20

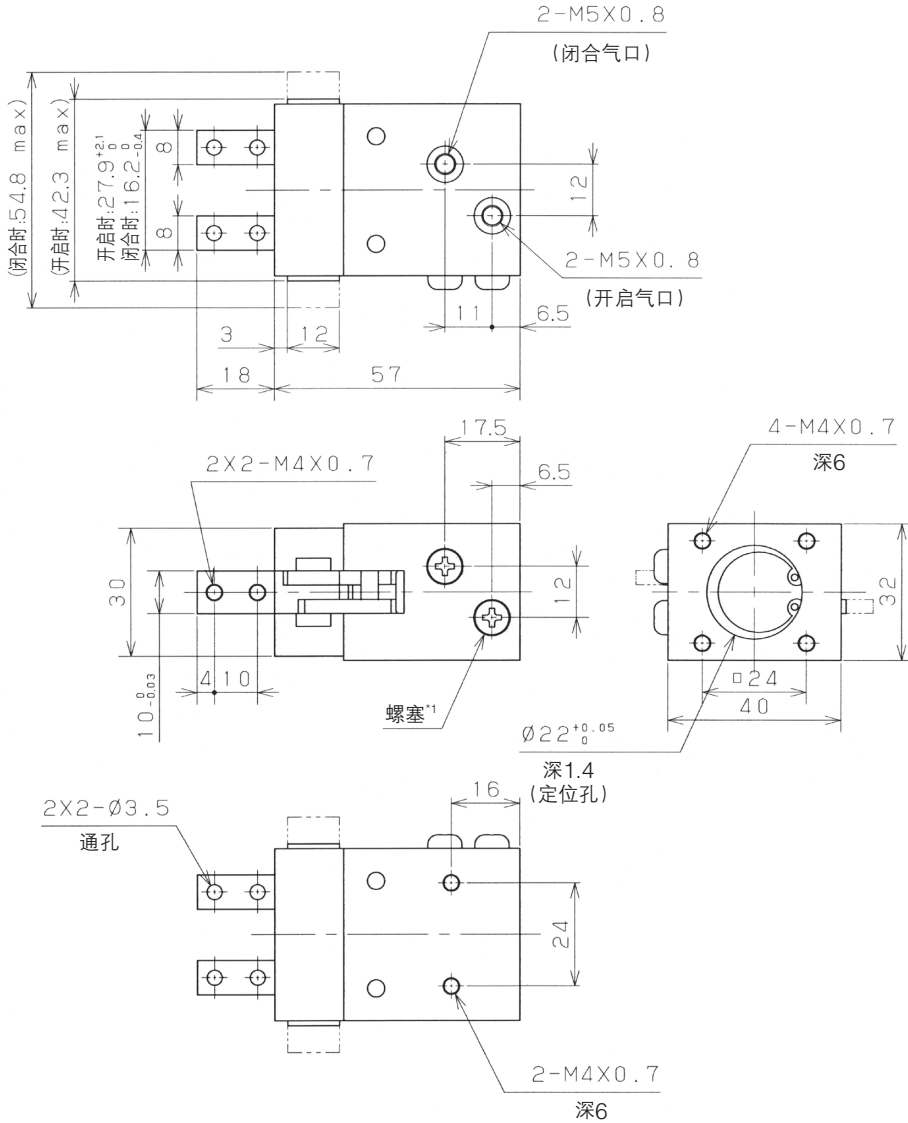

*1) 两个面上均设有气口, 请根据安装状态选用。

(C)KH(L)系列

平行气爪

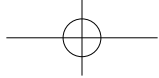

外形尺寸图 KHL-32

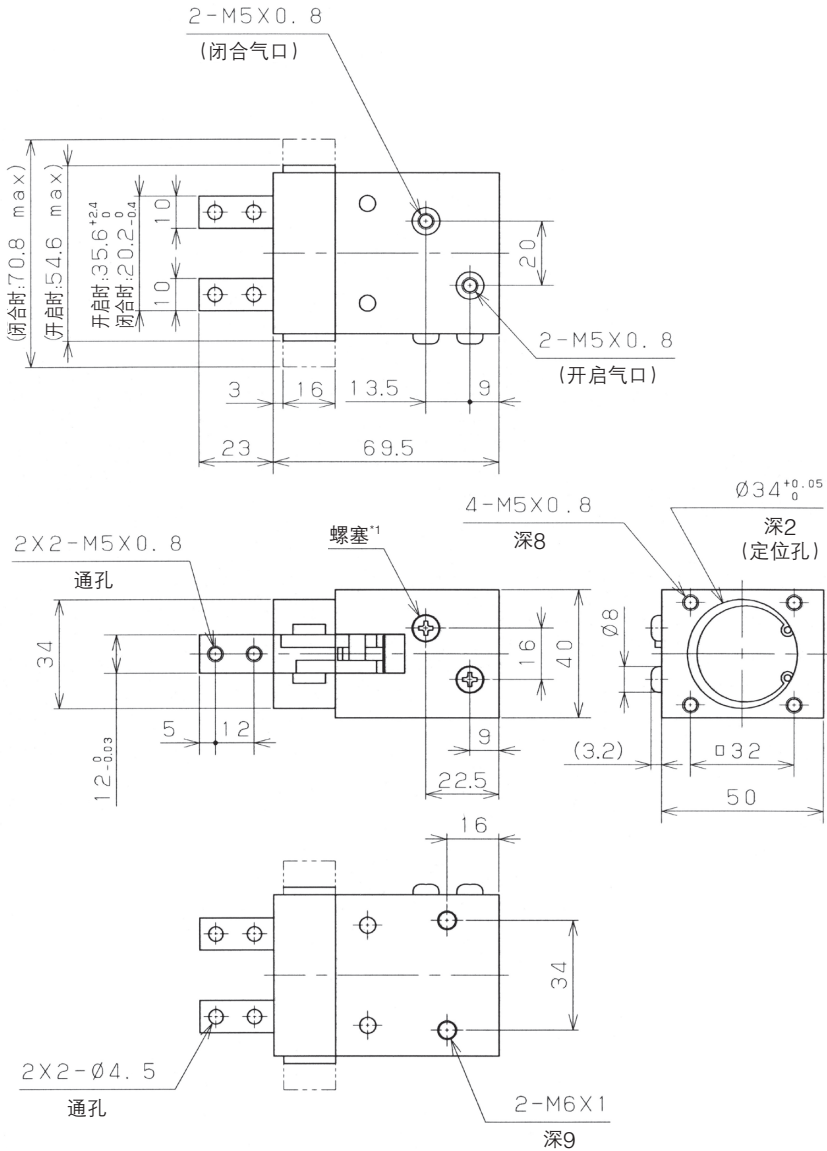

(C)KHL系列

平行气爪

*1) 两个面上均设有气口, 请根据安装状态选用。

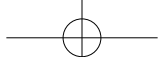

平行气爪

(C)KH(L)系列

备有CAD数据

外形尺寸图 CKHL-16

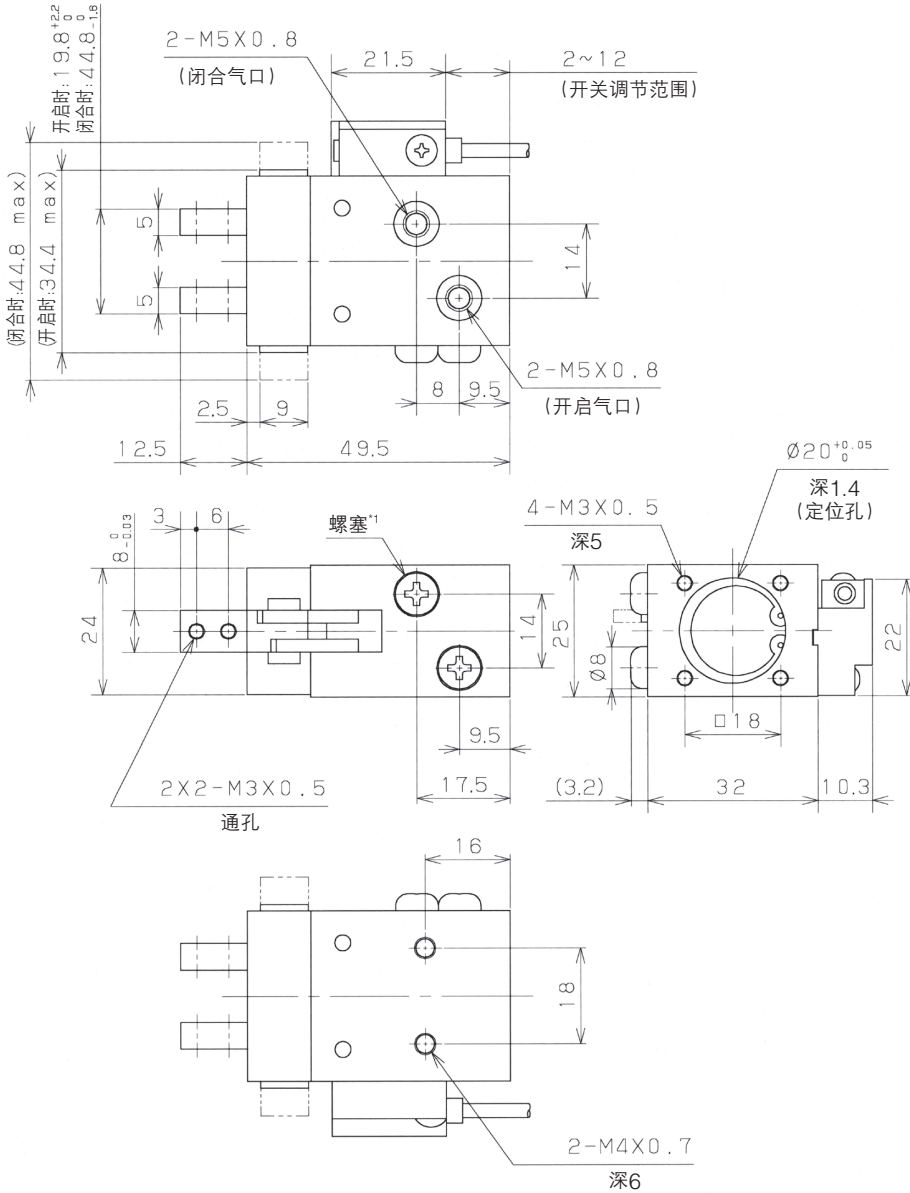

(C)KH(L)系列

平行气爪

*1) 两个面上均设有气口, 请根据安装状态选用。

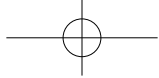

外形尺寸图 CKHL-20

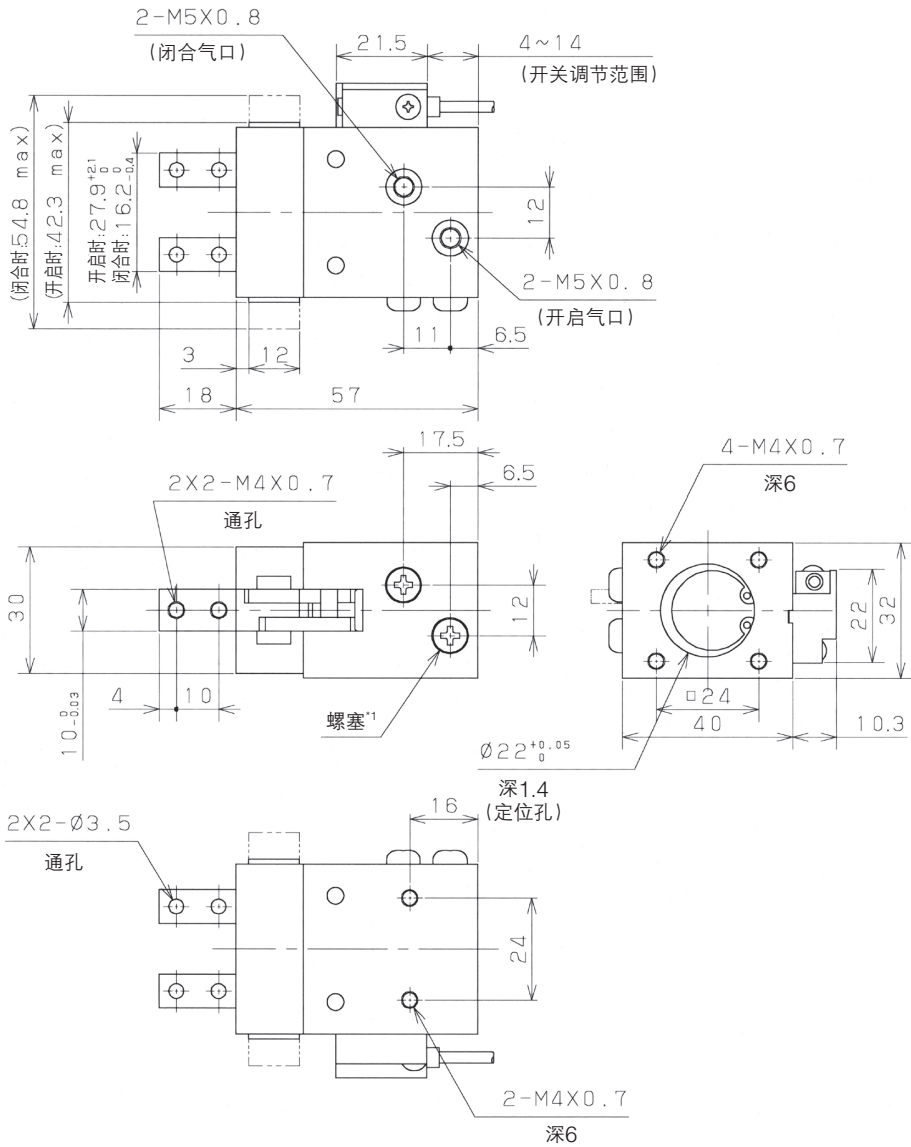

(C)K(H)(L)系列

平行气爪

*1) 两个面上均设有气口, 请根据安装状态选用。

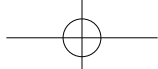

平行气爪

(C)KH(L)系列

备有CAD数据

外形尺寸图 CKHL-32

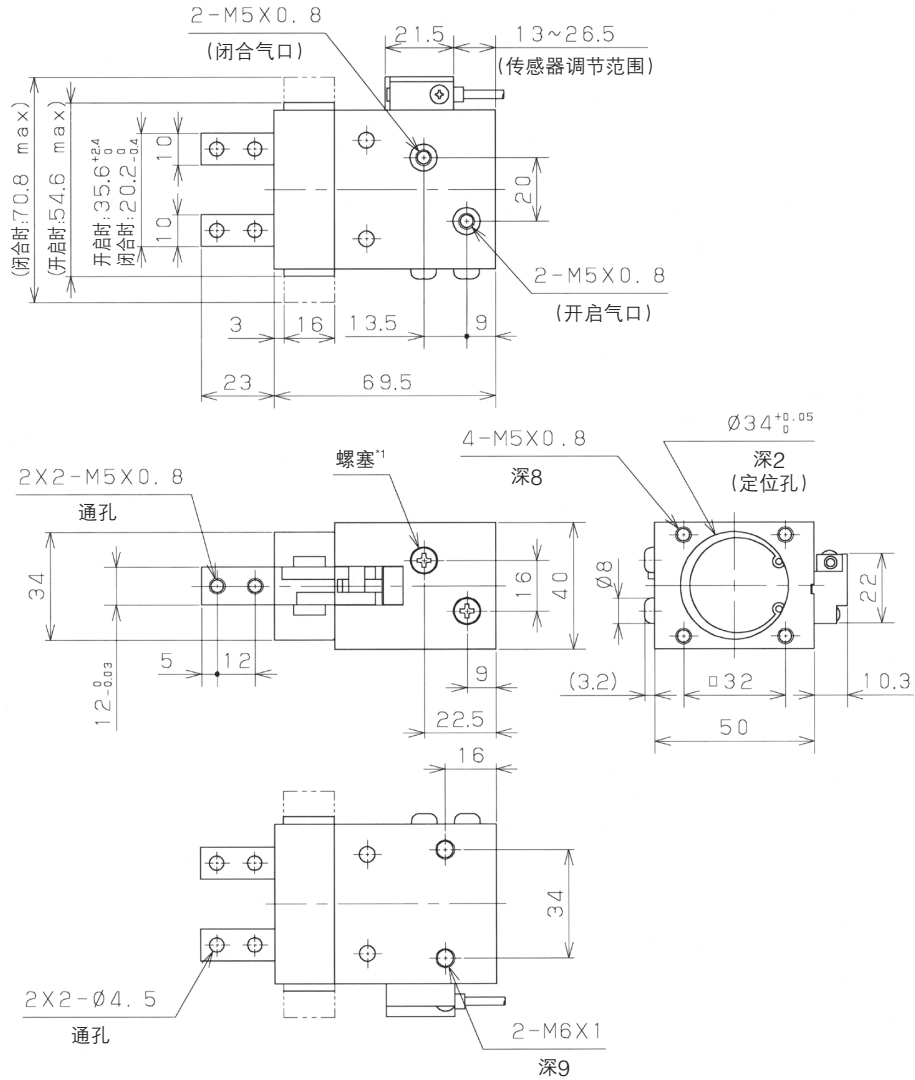

(C)KH(L)系列

平行气爪

*1) 两个面上均设有气口, 请根据安装状态选用。